

Carmel Coffe Table - 60x60

Designed by OEO - 2021



ITEM NUMBER	Carmel Coffee Table , 60x60 Rock Red / Black Semi Matt Base	10117296
	Carmel Coffee Table , 60x60 Pacific Blue / Black Semi Matt Base	10117297

DESCRIPTION A family of hybrid coffee tables intended for both indoor and outdoor use, the Carmel Table Collection by OEO Studio introduces ceramic to the GUBI material palette. Made with single-fired Italian stoneware and available in three sizes, the tables are finished with a protective high-gloss colored glaze that gives them vibrance and energy, evoking the carefree bohemian lifestyle of the Californian coast.

Materials & Finishes

TABLE TOP FINISH Rock red , Pacific Blue



BASE FINISH Black Semi Matt, RAL 9004



Dimensions

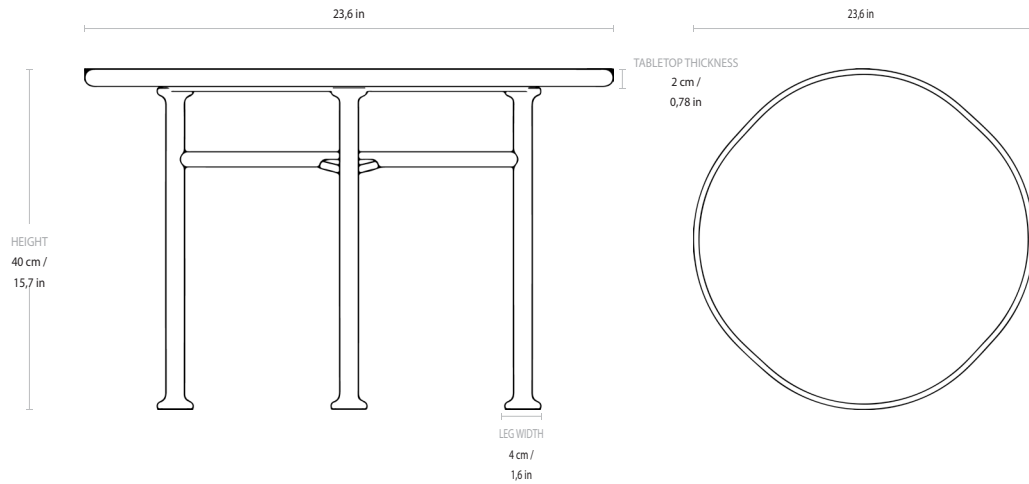

WIDTH	60 cm / 23.6 in
LENGTH	60 cm / 23.6 in
HEIGHT	40 cm / 15.7 in
TABLE TOP THICKNESS	2 cm / 0.78 in
DIAMETER OF COLUMN/LEG	2 cm / 0.78 in

Weight

TOTAL WEIGHT	15,1 kg / 33.3 lbs
TOTAL PRODUCT WEIGHT	12,8 kg / 28.2 lbs
TABLE TOP WEIGHT	10.8 kg / 23.8 lbs
BASE WEIGHT	2 kg / 4.4 lbs

Number of parcels

Number of parcels	2
PACKAGING 'NAME'	BASE
PACKAGING LENGTH	83 cm / 32.6 in
PACKAGING WIDTH	56 cm / 22 in
PACKAGING HEIGHT	5 cm / 2 in
PACKAGING WEIGHT	0.8 kg / 1.7 lbs
GROSS WEIGHT	3.3 kg / 7.2lbs

PACKAGING 'NAME'	TABLETOP
PACKAGING LENGTH	65 cm /25.6 in
PACKAGING WIDTH	65 cm / 25.6 in
PACKAGING HEIGHT	10 cm / 3.9 in
PACKAGING WEIGHT	1.5 kg / 3.3 lbs
GROSS WEIGHT	12.3 kg / 27.1 lbs

Test & Certifications

SALT SPRAY TEST NSS UNI EN ISO 9227:2017

SUSTAINABILITY Carmel Coffee table base is shipped flat packed in a plastic-free cardboard packaging.

Glides

HYBRID TOUGH RUBBER GLIDES Attached as standard

KEY FEATURES The table comes flatpacked and is a hybrid, which makes is usable both indoors and outdoors without.
