

## ETHIA

[ *Jai Jalan* ]

Modello depositato / Registered model



### Caratteristiche Tecniche

**Struttura:** in legno, imbottita in poliuretano con densità differenziata.

**Imbottitura sedile:** piuma con inserto di poliuretano a densità differenziata e Mind, in fodera di tela antipiuma.

**Schienali:** in metallo e piuma con inserto di poliuretano a densità differenziata e Mind, in fodera di tela antipiuma.

**Cuscini schienale:** Flyn-piuma (piuma e fibra di poliestere) in fodera di tela antipiuma.

**Rivestimento:** tessuto e pelle completamente sfoderabile.

### Technical features

**Structure:** in wood, padded with polyurethane in various densities.

**Seat padding:** feathers with an insert in polyurethane in various densities and Mind, all enclosed in feather-proof fabric.

**Backrests:** in metal and feathers with an insert in polyurethane in various densities and Mind, all enclosed in feather-proof fabric.

**Backrest cushions:** Flyn-piuma (feathers and polyester fibre) enclosed in feather-proof fabric.

**Cover:** completely removable fabric and leather.

# ETHIA

[ *Jai Jalan* ]

Modello depositato / Registered model

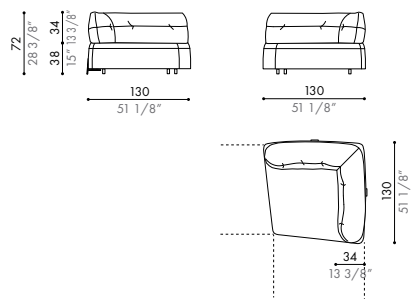
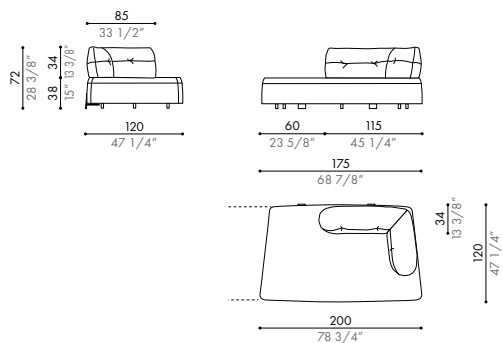
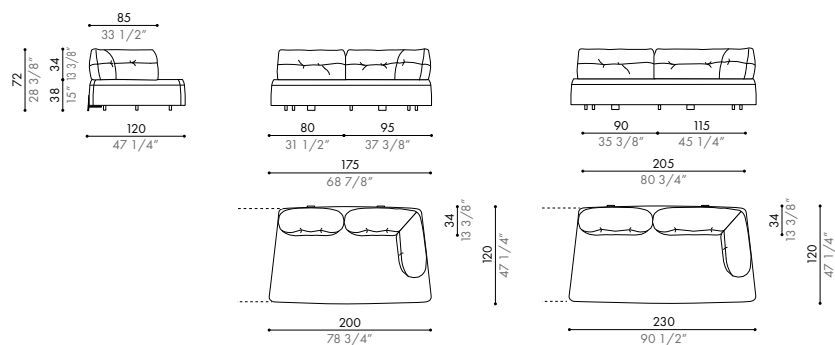

# ETHIA

[ *Jai Jalan* ]

Modello depositato / Registered model

